

# **HELICOPTER AND MULTIROTOR** **PROFICIENCY TESTING**

---



## **INDEX**

- 1. INTRODUCTION**
- 2. DEFINITIONS**
- 3. TEACHING A PUPIL PILOT TO FLY**
- 4. PUPIL PILOT MILESTONE LOG**
- 5. PREFLIGHT CHECKLIST HELICOPTERS**
- 6. PREFLIGHT CHECKLIST MULTIROTOR MODELS**
- 7. THE PROFICIENCY TESTS HELICOPTERS**
- 8. THE PROFICIENCY TESTS MULTIROTOR MODELS**



Feb 2015

# **SECTION 1**

## **INTRODUCTION**

Due to the unprecedented and ever increasing popularity of the multirotor models, it has become necessary that they be incorporated into the “line of sight” flying at SAMAA Registered flying fields.

So following numerous requests from the SAMAA and the Multirotor group, multirotor models have been accepted into the Helicopter SIG and the Helicopter Proficiency Manual has been updated to include information and schedules to accommodate these Multirotor models.

As Helicopter Proficiency tests have been in use since 2006, and in that Multirotors and Helicopters have common principals, it was decided that Helicopter tests, modified where required, would be the basis for proficiency testing for Multirotor models.

When reading this Manual please bear in mind that this Manual was originally written for helicopters and trying to differentiate between Helicopters and Multirotor in the general text in sections 2,3 and 4, will be confusing, so to clarify, Sections 6 and 8 of the Manual are Multirotor model specific, but in sections 2,3 and 4 the word Helicopter must be understood to refer to multirotor models as well.

In the interest of the hobby and safety, it is essential that:

- An adequate standard be achieved before a beginner be allowed to hover and fly on his own without a qualified instructor in attendance.
- Further challenges must be set to ensure and entice the model pilot to improve his flying skills.

With these two main objectives in mind, MHSA have researched, collected and correlated information on proficiency tests for helicopters which are well proven and internationally accepted, and with assistance from the local Multirotor flyers have expanded to include tests for Multirotor models..

The booklet’s main functions are:

- To outline some of the basics of both helicopter and multirotor flying.
- To define many of the terms used or applied to the hobby.
- To help ensure that the pupil pilot is given a grounding in the SAMAA, MHSA and club safety rules and the etiquette applicable to the flying field.
- That he be taught to fly in an acceptable and structured sequence with milestone targets.
- To ensure that at the end of this learning or teaching period, he will have achieved a level of competence “solo exemption” that will allow him to fly safely, without a club instructor in attendance when other members, spectators or people are present.
- To define the test maneuvers which he must perform in front of the judges to be awarded his hover and solo proficiency rating.
- To define further tests which allow him the opportunity, if he so wishes, to progress on and achieve higher levels of proficiency.
- To define the requirements needed to:
  - (i) fly at airshows
  - (ii) become a club Instructor.

There can be little doubt that the flying of radio controlled helicopters is the most challenging of all remote controlled flying model classes. “Most challenging” does not mean that it is either the ultimate or the best – that is for the individual to decide for himself.

This booklet does not and will not go into the technicalities and aerodynamics or how and why a helicopter flies. That subject we will leave for a braver writer. This booklet will set down the guidelines for the checking of equipment and

the stages suggested for a helicopter pilot to learn to fly and at a later stage improve, advance and as his competence increases, obtain higher merit qualifications.

The reader must realize that helicopter flying is still a fairly young art in South Africa and there are not as many experienced pilots as one could wish for, especially when one is looking for an instructor or judge.

It is therefore a fairly extended period of learning, and like all unfamiliar sports, ability comes with practice, and practice means hour upon hour of repeating the same exercise. There is no quick fix, but definitely a simulator or buddy box will assist with this learning phase.

For the average pupil pilot it is necessary to give the very basic explanation of how a helicopter flies and the controls involved in producing motion. Those of you who can fly helicopters please be tolerant, this is a "bare bones" explanation and does not attempt to point out the more complex issues involved.

The modern model helicopter is a heavier-than-air craft that derives its lift from driven rotor revolving on a vertical axis above the fuselage. Helicopters can rise and descend vertically, hover and move forward and backwards, or sideways.

The main rotor, a 2 or more bladed unit, is driven from an engine mounted in the fuselage, through gears, to reduce the rotor blade speed. An important and essential additional feature is the tail rotor which is mounted at the tail and is coupled to the main drive so as to counter the torque of the main rotor whatever the pitch setting is.

The main rotor has two pitch systems.

Collective pitch allows the helicopter to rise or descend vertically. The individual rotor blade pitch angles are changed by the same amount, relative to each other, at all times.

Cyclic pitch allows the helicopter to roll left or right or to pitch forward or backwards. The rotor blade pitch angles are changed by different amounts at various points on the rotor disc, i.e. to bank to the left you would increase the pitch on the blades on the right side at the rotor and reduce it on the left. (This is not quite true as gyroscopic precession comes into play, but is good enough to understand how the helicopter moves about.)

Now in the model, as with the real helicopter, these two systems are mechanically coupled to the rotor but their independence is retained for the control functions, making this a very complex unit, which is fairly expensive, hard to repair and which needs "setting up" if the model is to fly well.

Ok, that is the extent of the information you will get on helicopters in this booklet.

One word of advice, if you have not yet bought a helicopter – buy one, preferably new (the development of helicopters is such that last years' model is out of date – if finances allow, buy new), a model which is readily available and for which spares are reasonably priced and available at short notice, preferably buy one that is a well known make, which is flown by members of your club, and is available, together with spares from your local specialist helicopter hobby shop. See the product before you buy, find out if the items, i.e. motor, radio and gyro are compatible, and to be on the safe side, have the seller give you a flight demonstration and what about a guarantee?

A 4 channel radio will NOT work on a modern collective pitch helicopter. It is advisable, and cheaper in the long run to buy radio equipment specially designed for use in helicopters. Preferably a computer radio with at least a 5-point pitch and throttle curve function.

Now, a word or two of caution:

It cannot be repeated too often, the main ingredient required by anyone wishing to fly model helicopters is sheer determination and perseverance.

It is true that the latest model helicopters are improving in leaps and bounds but, if you are not committed, don't waste a considerable amount of money and your time!

As a general rule, those who fly fixed wing models will find helicopters more difficult to fly than a person with no preconceived principals.

The fixed wing flyer will have to unlearn, or forget a number of principals and automatic responses he learnt over the hundreds and thousands of flying hours. The ex-fixed wing pilot will have got the left / right issues figured out while the machine is flying towards him.

A final word of advice – WHEN IN DOUBT – DON'T.

## SECTION 2

### DEFINITIONS

For clarity, let's define some of the terms and descriptions used in this Booklet, in many cases these are general to the flying field but are applicable, these are as follows:

<i>Pupil Pilot</i>	A Pupil Pilot is a member who is learning to fly a R/C model helicopter. He will have SAMAA membership but has not as yet obtained his "Solo" status. HE SHALL ALWAYS BE ACCOMPANIED BY AN EXPERIENCED SAMAA REGISTERED AND QUALIFIED CLUB INSTRUCTOR.
<i>Pilot</i>	A member who is in charge of a model helicopter, who can fly and has achieved the minimum qualifications of a "Solo". When he switches on his radio transmitter he becomes a Pilot.
<i>SAMAA</i>	South African Model Aircraft Association. It is the Coordinating and Controlling Body for Aeromodelling in South Africa. All SAMAA Rules and Regulations are to be incorporated in and enforced at SAMAA registered clubs.
<i>MHSA</i>	Model Helicopters of South Africa is the special interest group within SAMAA. MHSA coordinates and controls all helicopter and multirotor activities within South Africa.
<i>AMA</i>	Academy of Model Aeronautics. The American equivalent of SAMAA.
<i>FAI</i>	Federation Aeronautique Internationale. The International sporting body of aviation.
<i>Member</i>	A fully paid up member of MHSA who is in good standing with the association. MHSA membership also requires SAMAA membership.
<i>Pilot Box/Pilot Area</i>	The designated area from which pilots fly their helicopters or multirotor models
<i>Frequency Peg Board</i>	The frequency control system used by the club to ensure control over all the frequencies which can be used at the field.
<i>Pit Area</i>	The area between the club house and the Pilot boxes on the runway nearest to the club house.
<i>Run Up Area</i>	An area off to the side of the taxiways where engines can be checked without interfering with aircraft and helicopters in the pit area or the Pilots flying.
<i>Transmitter Control</i>	The designated area where all unused transmitters are impounded.
<i>Transmitter</i>	A purpose made, commercially manufactured unit which shall have been designated and manufactured to work within the tolerances of the frequency band without interfering with the adjacent frequency bands. It is used to control our helicopters.
<i>Buddy Box</i>	Two transmitters connected together via a cable, whereby the Instructor has the "master" transmitter and can assume control of the helicopter as required. This system avoids the traditional method of grabbing the transmitter from the pupil when a mistake is made.
<i>Frequency Peg/Marker</i>	The marker used to identify the radio frequencies in use at the field. This could be either the "PEG ON" or "PEG OFF" system of control.
<i>Fixed Pitch</i>	Normally only used on the <u>simplest</u> types of helicopters, and is when the rotor blade angle is fixed and lift controlled by varying the rotor speed.
<i>Variable Pitch</i>	Refers to the fact that the main rotor blades are hinged or pivoted in such a way that the angle of each blade can be altered to give different motions.

<i>Collective Pitch</i>	Collective pitch allows the helicopter to rise or descend vertically. The individual rotor blade pitch angles are changed by the same amount, relative to each other.
<i>Cyclic Pitch</i>	Cyclic pitch allows the helicopter to roll left or right or to pitch forward or backwards. The rotor blade pitch angles are changed by different amounts at various points on the rotor disc.
<i>Pitch Curve</i>	The electronically selected pitch settings of the main rotor blades. (collective pitch system) It is done on a computer radio.
<i>Throttle Curve</i>	The electronically selected throttle settings for the carburetor. It is also done on a computer radio.
<i>Main Rotor</i>	This is the main component of a helicopter and consists of 2 or more blades attached to a shaft which is driven by the motor through gearing to reduce the speed and whose blade angles are controlled by servos and signals sent out by the pilot.
<i>Swashplate</i>	The device used to convert the 'fixed' servo control inputs on the main mechanics to the rotating inputs required at the rotor head
<i>Rotor Head</i>	The attachment points for the rotor blades and fly bar. Normally a fairly complex part of the helicopter which is used to control the angle of the main rotor blades so as to produce upward, forward or sideways motion in the helicopter.
<i>Tail Rotor</i>	this is the small rotor on the tail of the helicopter fuselage which counteracts the torque of the main rotor and balances the helicopter.
<i>Fly Bar</i>	The 3 or 4mm shaft which is perpendicular to the main rotors and has a set of paddles mounted to it. Their purpose is to stabilize and assist in the controlling of the helicopter.
<i>Hovering</i>	is when the model has lifted off the ground and is controlled to remain stationary above the take off point. This is regarded as the first milestone in helicopter flying.
<i>Tracking</i>	The mechanical adjustment of the pitch on one rotor blade to get the rotor tips to 'fly' at the same height. It is normally checked just before the point of lifting off.
<i>Trimming</i>	this is required when a model, on lift off, tends to head off in one direction or turn one way. It is recommended that this trimming be done by an experienced pilot.
<i>Tail In</i>	this is the usual position used when you first start to fly a helicopter, it is the safe position, with the nose of the helicopter into the wind and the tail towards you. This same term will be used for multirotor models, when referring to the back of the model being towards the pilot.
<i>Ground Effect</i>	when you are hovering (usually at a height less than rotor diameter) the model will be difficult to keep stationary due to the downwash from the rotor blades, climbing a little higher out of the ground effect makes things become smoother.
<i>Orientation</i>	At some stage you will find that you are unsure of the models attitude and direction. This is disorientation, it has nothing to do with eyesight, but rather with the fact that you are unable to relate the information you see to the actions needed to recover control. Fortunately with practice and experience this problem will eventually disappear.
<i>Simulator</i>	The simulator is a computer program which allows you to fly a model on your home PC using your transmitter as the control without the risk of crashing and destroying your real model. Irrespective of the number of negative statements made against simulators, they certainly help a pilot to obtain the necessary coordination and manual dexterity to succeed. They can and do make many pilots overconfident. Many simulator packages are presently on the market and you should get the advice from the helicopter pilots at your field.

*Rules and Regulations*

SAMAA Manual of Operations, MHSA Rules and Safety Regulations, the Club Rules and Regulations. Club By-Laws (which have been specifically written to accommodate any club or external restrictions or requirements).

*Multirotor Model*

A model aircraft which flies by the use of two or more independent propellers, linked by electronic stability control so as to allow the pilot to fly the model remotely, where and as he wants, using a hand held transmitter.

# **SECTION 3**

## **TEACHING A PUPIL PILOT TO FLY**

This section has been introduced to set down some guidelines to Club Instructors.

It is intended to outline the things that a pilot should know, and its objective is to assist and remind the Instructor of things that he takes for granted and assumes others know.

The duties of the Club Instructor are four fold:

### **3.1 CHECKOUT THE PUPIL/BEGINNER'S HELICOPTER**

Every helicopter should be checked out for correct motor and equipment installation and for correct radio/helicopter setup.

It is suggested that the preflight checklist in Section 5 be used for this purpose.

### **3.2 FIELD ETIQUETTE AND SAFETY RULES**

At this stage most clubs have not prepared classes to cover this aspect of the hobby and therefore it is up to the Instructor to run through the Club Constitution book and documentation covering:

1. – Club Rules and Flying Procedures;
2. – Safety Rules, Safety Code and Procedures; and
3. – Bye-Laws and Special Regulations.
4. – SAMAA and MHSA Rules.

### **3.3 GENERAL INSTRUCTION**

The Instructors' third duty covers a fairly large scope and the Instructor must do his best to cover the subjects listed below.

To date, no course has been prepared, so it is up to the Instructor to do his best to give the Pupil a grounding in the following:

#### **3.3.1 Theory of Flight**

1. basics.
2. rotor speed.
3. rotor blade pitch / angle.
4. ground effect.
5. the 3 axis (yaw, pitch, roll).
6. flight controls.
7. Torque/tail rotor.
8. air density and temperature.
9. mass and blade loading.

#### **3.3.2 Radio Functions**

1. very basic theory.
2. actions and functions of Tx.
3. actions and functions of Rx.
4. checks, range, batteries, etc.
5. gyro functions.
6. maintenance and charging.
7. receiver "failsafe" settings.

### **3.3.3 Frequency Control**

1. Describe both systems used in South Africa, i.e. “PEG ON” and “PEG OFF” in detail, emphasising discipline and consequences of failure to observe the rules.
2. Transmitter impound system.

### **3.3.4 Pre-Flight Checks**

1. radio in correct hover mode and at idle setting.
2. control checks.
3. lift-off discipline.
4. allocated flying area, procedures and clearance, permission from other Pilots flying.
5. club local flying and safety rules.

### **3.3.4 Flying**

1. power and collective pitch for height.
2. cyclic and tail rotor for movement.
3. acquisition of stick “feel” – practise.
4. simple hover and correction during manoeuvres.
5. take-off procedures.
6. touch down.
7. normal turns and manoeuvres.
8. engine power limits
9. Hover Proficiency Test
10. disorientation - stick time.
11. dangers of flying through the sun.
12. accurate positioning of helicopter in the sky.
13. approach and landing pattern.
14. Basic aerobatics.
15. identification of pupil’s weakness, revision and practise to improve.
16. first solo flight.
17. Solo Proficiency Test.
18. one month check-up and correction of any problem.

## **3.4. FLIGHT TRAINING**

Now comes the hard work for the Instructor – teaching the Beginner or Pupil to fly.

**NO PUPIL PILOT MAY FLY HIS HELICOPTER OR MULTIROTOR MODEL FROM THE FLIGHTLINE UNLESS ATTENDED BY AN AUTHORISED CLUB MEMBER.**

Once the Pupil has listened to all the above theory, has forgotten more than half and misunderstood a quarter, he is now ready to fly, but again only after:

### **3.4.1 Pre Flight Checks**

1. Refuel if necessary.
2. Check control movements.
3. Check Tx in correct hover mode and at idle stick position before starting the engine.
4. Explain “aerial theory” of orientation (don’t point aerial at helicopter).
5. Explain stick movements, and use of trims and rates if necessary.
6. Explain position of hands and fingers on the transmitter.
7. Give commands to pupil and check his response to positioning helicopter.

### **3.4.2 Flight Checks**

1. Check and adjust trims on transmitter.
2. Land immediately if trims are way-out or helicopter behaves abnormally.
3. After test flight, land and adjust trim, throttle and pitch curves on the transmitter.
4. Re-check in flight, re-adjust if necessary



### 3.4.3 **TEACH THE PUPIL PILOT TO FLY**

#### **Flying – Sequence of Teaching**

Here each Instructor has his own individual idea as how best to teach a Pupil, but the basics throughout the world show that in most cases the Instructor is an observer who adds moral support and ensures that the required corrective action is taken. The use of computer simulators and buddy box training is strongly recommended.

The pupil will then do hours and hours of lift offs and hovering and will slowly progress along the learning sequence set out in section 4 of this booklet.

- Tail in hover.
- Tail in squares and circle.
- Tail in Figure 8.
- Side on hover (both sides)
- Figure eight.
- Forward flight.
- Nose in hover
- Circuits and hover.
- Autorotation
- High speed flight.
- Advanced circuits.

The Instructor's job is well done and he is a mental wreck, but guess what...there will still be dozens of new members over the years who will still want to learn to fly!

We believe that some of the points which must become part of the Instructor's vocabulary ad nauseam are:

- Is your peg on the board?
- Have you charged your batteries?
- Have you checked out your helicopter?
- Have you fuelled up?
- Have you switched on?
- Mind/be careful of the spinning rotor.
- Pull out your aerial.
- Keep away from the pits.
- Get more height.
- Tell the other members your intentions.
- Have you switched off?
- Is your transmitter back in the Tx impound?

# **SECTION 4**

## **BEGINNERS/PUPIL PILOT MILESTONE LOG**

### **4.1 PUPILS/BEGINNERS MILESTONES**

This section now sets out the proposed learning – “achievement milestones” for teaching Pupils and to help achieve uniformity we have produced a Progress Log, we suggest that these milestones become a club standard in that any Instructor can see at a glance the status and progress of the Pupil, and carry on instruction from that point.

A suggestion to clubs is that a cardboard print of the Progress Log be issued to the Pupil, and this card is then presented to the Instructor before a Pupil flies. This card is then finally signed off by the Instructor and the Club Safety Officer.

A copy of the Progress Log/Milestones Achieved follows (See next page):

# HELICOPTER TRAINING

## PROGRESS LOG

Member's Name: \_\_\_\_\_ Type of Helicopter: \_\_\_\_\_

Club Name: \_\_\_\_\_ SAMAA Number: \_\_\_\_\_

Item	Flying	Ground	Signature and Date
1	Explain Frequency Control System, Control Functions, Movement of Sticks, Hovering Criteria to pupil.	Demonstrate Frequency Peg System. Explain Basic Safety Rules, and Flying Rules.	
2	Helicopter checked out, setup ok, flies ok.	Airworthiness checklist ok.	
3	Pupil can lift off under control. Pupil can hover, into wind tail in.	Club Safety, field and Flying Rules known by pupil.	
4	Pupil can do tail in hover, tail in circle and figure 8.	Safety Procedures know and practiced by pupil.	
5	Pupil passes Hover Proficiency Test and qualifies to hover at any SAMAA registered club.	Safety and flying rules and procedures known.	
6	Pupil can do forward flight, figure eights, circuits, nose in hover and pirouettes.	Basic aerodynamics of helicopters known	
7	Pupil can do high speed flight, advanced circuits and basic aerobatics.	Basics of helicopter set up known.	
8	Pupil passes Solo Proficiency Test and qualifies to fly solo at any SAMAA registered club.	Has satisfied Instructor on knowledge of Safety, Club Rules and Basic helicopter Aerodynamics	

Instructor's Signature: \_\_\_\_\_ Date: \_\_\_\_\_

Safety Officer Signature: \_\_\_\_\_ Date: \_\_\_\_\_

# **SECTION 5**

## **PRE-FLIGHT CHECKLIST--- HELICOPTER**

**This checklist is a general checklist and should be used in part or in whole by all Pilots to check out their helicopters before the first flight of the day.**

This preflight checklist is to be used in whole by all Pilots who are doing their proficiency tests.

It is a prerequisite that any new, untried or repaired helicopter be properly checked before its first flight. The check-lists which follow are brief but reasonably comprehensive and, if in the views of the Instructor, the helicopter is not airworthy or is unsuitable for a Pupil, now is the time to say so. It is pointless for a Pupil to try to fly a helicopter which is not airworthy or too advanced for him which he will crash and which will convince him that this hobby is not for him.

It is worth remembering that the best helicopter with the best equipment that has been well built will still be un-flyable if not set up correctly.

If the helicopter fits the above category, it should be grounded until such time as the alterations, modifications or replacement is done to the satisfaction of the Instructor. A list of the defects, if not fixable at the field, should be given to the Pupil by the Instructor. A copy of this same list must be given to the Safety Officer with the Pupils name, the type of helicopter, and his reasons for not allowing the helicopter to be flown clearly documented thereon.

### **CHECK LIST:**

#### **5.1 Structure and Mechanics:**

1. Check main frames for cracks.
2. Check structure for loose items.
3. Check rotor blades for nicks, cracks, etc.
4. Check balance of main rotor blades.
5. Check fly bar weights for tightness.
6. Check fly bar paddles for damage and alignment.
7. Check tail boom for damage.
8. Check tail rotor for nicks, cracks and correct installation.
9. Check tail blades turn in correct direction, ie belt drive correctly installed.
10. Check fins for damage.
11. Check skids for damage and tightness.
12. Check fuel tank and fuel tubing for perishing.
13. Check fuel filter installed and not blocked.
14. Motor - Correct size and type (helicopter)
15. Glow Plug - correct type and correctly installed
16. Carburettor - mounted firmly and default needle settings.
17. Silencer - Suitable helicopter exhaust and properly installed
18. Check all ball links for excessive ware or over tightness.
19. Check swashplate for movement and ware.
20. Check autorotation hub (if fitted)
21. Check position or CG.
22. Check tracking of main rotor blade

#### **5.2 Radio Installation:**

1. Check that suitable servo are installed correctly.
2. Check battery for suitable capacity and secure installation.
3. Check receiver position and protection.
4. Check aerial properly mounted and protected
5. Servo leads okay and plugged in properly.
6. Check gyro installation and integrity of double sided gyro tape.
7. Servos move smoothly with no grinding noises, jerkiness or buzzing.

### 5.3 **Helicopter Setup:**

1. Set all trims to neutral.
2. Check servo arms are perpendicular to pushrods.
3. Check cyclic controls in correct direction. (aileron + elevator)
4. Adjust servo to swashplate linkage to level the swashplate.
5. Check no servo or linkage binding on cyclic system.
6. Set hover "pitch curve" to default. (0,25,50,75,100)
7. Check the main blade pitch range available.
8. Adjust to a suitable range and check no binding of collective system.
9. Set hover "pitch curve" to suitable hover requirements.
10. Set hover "throttle curve" to default. (0,25,75,100)
11. Check the throttle movement is in correct direction and full range.
12. Set hover "throttle curve"
13. Set "throttle hold" idle and pitch settling.
14. Check idle up 1 and 2 / St1 and St2 are either set up properly or disabled if not required
15. Check tail servo moves in correct direction from the Tx stick movement.
16. Check tail servo moves in correct direction from gyro (ie helicopter yaw)
17. Set gyro gain to suitable starting point.
18. Check for no binding of tail system.
19. Set up dual rates if thought necessary
20. Set up exponential rates if thought necessary.
21. Check failsafe settings on servos if PCM receiver used.
22. Check battery voltage.

# **SECTION 6**

## **PRE-FLIGHT CHECKLIST-- MULTIROTOR MODELS**

**This checklist is a general checklist and should be used in part or in whole by all Pilots to check out their Multirotor models before the first flight of the day.**

This preflight checklist is to be used in whole by all Pilots who are doing their proficiency tests.

It is a prerequisite that any new, untried or repaired Multirotor model be properly checked before its first flight. The check-lists which follow are brief but reasonably comprehensive and, in the views of the Instructor, the Multirotor model is not airworthy or is unsuitable for a Pupil, now is the time to say so. It is pointless for a Pupil to try to fly a multirotor model which is not airworthy or too advanced for him which he will crash and which will convince him that this hobby is not for him.

It is worth remembering that the best multirotor model with the best equipment that has been well built will still be un-flyable if not set up correctly.

If the multirotor model fits the above category, it should be grounded until such time as the alterations, modifications or replacement is done to the satisfaction of the Instructor. A list of the defects, if not fixable at the field, should be given to the Pupil by the Instructor. A copy of this same list must be given to the Safety Officer with the Pupils name, the type of multirotor model, and his reasons for not allowing the multirotor model to be flown clearly documented thereon.

### **CHECK LIST:**

#### **6.1 Structure and Mechanics:**

1. Check main frame for cracks.
2. Check structure for loose items.
3. Check propellers for nicks, cracks, etc.
4. Check motors for debris.
5. Frame not loose.
6. Frame Condition.
7. Check position or CG.
8. Check motor alignment.

#### **6.2 Radio and equipment Installation:**

1. Check that suitable ESC are installed.
2. Check battery for suitable capacity and secure installation.
3. Check that no wires are Loose.
4. Batteries Charged.
5. GPS Correct and secure ( not to be operable for test).
6. Tx Charged.
7. Check receiver position and protection.
8. Check aerial properly mounted and protected.
9. ESC leads okay and plugged in properly.
10. Check IMU installation and integrity of double sided IMU tape.

#### **6.3 Multirotot Model Set up:**

1. Check CORRECT Model selected.
2. Set all trims to neutral.
3. Check propellers for direction.
4. Check retracts tight, if fitted.
5. Check the throttle movement is in correct direction and full range.
6. Set gyro gain to suitable starting point, per manufacturer's specification.
7. Check failsafe settings on servos if PCM receiver used.
8. Check battery voltage.
9. Check AV Signal.

10. Check gimbal Calibration.
  11. Check battery Alarm connected.
  12. Check ESC Wiring Good.
  13. Check camera wiring good (not for test).
  14. SD card in camera (not for test).
  15. Check SD card formatted (not required for test)
  16. Check IMU secure.
  17. Confirm IMU STATUS.
  18. Check Gyro zero.
  19. Check bubble level
- Check Parachute installation

#### 6.4 Multi-Rotor Trouble Shooting

**Below are listed some of the most common problems encountered with multirotor models, it is suggested that if you cannot resolve a problem, discuss it with others or refer it to a specialist.**

- No motor start
- No TX/RX communication
- Gimbal Failure
- Flip on Take-OFF
- Lack of RPM
- No Power on craft
- Craft Oscillation
- Craft Speed too fast / Slow
- Craft Unstable
- Video Unstable
- In-flight GPS loss
- Prop shadow in view
- Back landing not activating
- Limited Height / Distance
- Batteries swollen

# **SECTION 7**

## **THE PROFICIENCY TESTS -- HELICOPTERS**

The primary purpose of proficiency testing is to improve the skill level of the pilot. This applies equally to a newcomer who is learning to hover and to an advanced pilot perfecting aerobatics.

The tests have been split into four classes. Hover Proficiency, Solo Proficiency, Advanced Proficiency and Instructor Proficiency.

In the past we used the AMA Class 1, 2 and 3 competition classes as the Bronze, Silver and Gold and then the FAI F3C as the Instructor test. This created a problem as the Class 1 / Bronze was used as the “solo” test and it only had hovering maneuvers and a pilot that can hover is possibly far from competent to fly around and the Class 2 / Silver was actually too difficult to be used as the “solo” test.

We now use the AMA Class 1 for the Hover Proficiency, a simplified Class 2 for the Solo Proficiency, Class 3 for the Advanced Proficiency and the FAI F3C for the Instructor Proficiency.

During the normal learning process of a helicopter pilot, the initial challenge is to learn to hover. The pilot needs to practice hovering and the hover maneuver skills for a fairly lengthy time before moving onto forward flight and flying maneuvers. At this stage the pilot should pass his Hover Proficiency Test. This will qualify the pilot to practice these hovering skills without the constant supervision of an instructor.

Once the hovering is at a high enough standard and the pilot wants to progress into forward flight, the instructor will be needed again. The instructor will teach the pilot how to fly the helicopter around. The pilot should then pass his Solo Proficiency Test. This will qualify the pilot to practice these hovering and flying skills without an instructor.

Pilots usually require input and advice from their instructors and other more skilled pilots to be able to continue the progression. The Hover and Solo Proficiency Tests should be seen as a “license to learn”.

The Advanced and Instructor Proficiencies are for further challenges for the more advanced pilots.

### **7.1 REQUIREMENTS FOR THE HOVER PROFICIENCY TEST**

The Hover Proficiency Test consists of an oral test, a pre-flight inspection and basic hover maneuvers. This qualification fulfills the minimum requirement of the SAMAA Insurance to hovering a model helicopter without an instructor present.

From the attached Hover Proficiency Test Sheet it can be seen that the maneuvers required are basic. This is intentional, the reason for this test is to demonstrate that you, the Beginner or Pupil, have enough knowledge of the club procedures and experience to hover, without an Instructor present, when there are other members flying and that you will not create a liability or danger to those present, including spectators and their possessions at the flying field.

Learning to hover and fly has always been at club level. The Hover Proficiency Test must therefore also be available to the local club pilot. To keep an acceptable standard, any two Club Instructors can test a pupil pilot and award a Hover Proficiency status, as long as neither instructor was the pupil’s primary instructor. The Club Instructors position is critical to the development of the flying expertise of members in the club

Each maneuver of the test is scored out of 10,

The first two items, Oral (general and safety) and Pre-flight, will require some homework from you.

The maneuvers must be flown once during the flight test.

The pass mark is an average of 50 %, with no less than 30 % for any individual maneuver.

The Judges pass/fail decision is final and not open to discussion.

If a pilot fails the test, he may be re-tested once on that day, if time allows.

The Hover Proficiency Test will be arranged and conducted in a formal manner, with a minimum of a Club/MHSA Instructor, a second judge holding a minimum of a Sole Proficiency, and the duly signed test papers forwarded to SAMAA.



Copies of questions for proficiency test  
TYPICAL QUESTIONS TO BE ASKED FOR ALL PROFICIENCY BADGES

All these questions should have been covered by your Instructor during your “learning to fly period” and if not, are covered in the SAMAA Manual of Operations which can be found on the SAMAA website [www.samaa.co.za](http://www.samaa.co.za)

1. Where do you find the “Rules” or Operational procedures applicable to model aircraft flying and have you read them?
2. Where do you find the National Helicopter Safety Rules and have you studied them?
3. Where do you find the Club By-Laws and have you read them?
4. Have you read and noted the Club Rules applicable to Helicopter flying at the field?
5. Which areas of your Club field are you not allowed to overfly (no fly zone) and why?
6. Who controls the “use of airspace” and are model flyers answerable to this body?
7. To which group is SAMAA and its Members affiliated.
8. Do you need to be a member of any organization or Club to fly?
9. Where can you legally fly?
10. Do you need a permit to fly?
11. What is your standard procedure when you arrive at the club?
12. What do you do if you are a visitor at a club and wish to fly?
13. What checks should you have you done before you go out to fly?
14. Why must you secure the frequency spot and place your peg on it before switching on your transmitter? What do you do if there is a peg on your frequency spot?
15. What do you do if you want to fly and your frequency spot is not on the board?
16. What would you do if you want to fly but left your frequency peg at home?
17. What would you do if you are about to fly and when you switch on your transmitter the meter shows red or under manufacturers recommended voltage?
18. How do you know that your Main Power or receiver battery it is OK to fly, for the first flight, and then for subsequent flights?
19. How often do you do a Radio range check?
20. When you fly should you have a person/spotter with you on the flight line?
21. What is the legal height to which you may fly your model aircraft?
22. What would you do if you see a full-size aircraft or helicopter is flying near or over your flying field?
23. Why is it dangerous to crawl under the rotors to adjust the needle valve when the rotors are spinning?
24. Why do the Club Safety Rules state that, you should not hover your helicopter, in the pit area?
25. What would you do if your motor stalls on the threshold/runway prior to take-off and other Pilots are waiting to take-off?
26. What would you do if on take-off, just after becoming airborne, your aircraft turns towards the pit/spectator area?
27. How do you know what direction the circuit is to be flown?
28. Which runway do you use for takeoff and landing?
29. What do you do if you accidentally crash into a parked car or person at the field?
30. Where do you stand when flying?
31. If you are going to land and see someone on the runway trying to retrieve an aeroplane, what would you do?
32. If you were lined up ready for take-off and during your final check you notice:
  - a. A servo jumping?
  - b. That the tail plane is loose?
  - c. That the helicopter is vibrating badly?
  - d. The skids on the helicopter are loose?
33. What would you do if you were a pilot on the flight-line and heard:
  - a. Someone shouting “DEADSTICK” - When you were about to take off?
  - b. Someone shouting “AUTO” or “LANDING” – When you were about to take off?
  - c. Someone shouting ‘crossing runway’?
34. If you are the most senior person at the field and the duty officer is not present, what would your duty be?
35. If you see a child running in the pit area, what would you do?
36. If you are the duty officer for the day, what would you do:
  - a. If someone is flying recklessly and ignoring the safety rules?
  - b. If after a verbal warning they still persist in ignoring the rules?
37. What are your duties if you are the safety officer of the day?
38. What is a “fail safe” receiver setting and how do you set it up?
39. Why are lithium batteries more dangerous than ordinary batteries?
40. Why are electric motor powered models dangerous?
41. When and where may you safely power up an electrically powered model aircraft?

42. What could happen if you turn off your transmitter without first disconnecting the power to the electric motor of your model?
43. How do you know the state and condition of your flight and transmitter battery packs?
44. What would you do if you notice that you forgot to switch off your transmitter an hour or so ago, and want to fly again?
45. What would you do if it starts to rain whilst you are flying?
46. What would you do if there is lightning whilst you are flying?
47. Where do you fly a helicopter at your field and if on the main field how may you fly?
48. What would you do if you are flying and the cell phone on you rings?
49. What would you do if you feel ill or faint while you are flying?
50. What would you do if you lose sight of your helicopter while flying?
51. What would you do if the throttle on your helicopter sticks at full throttle whilst flying?
52. What precautions should be taken when circumstances require a downwind landing?

#### TYPICAL ANSWERS TO THE ABOVE QUESTIONS

1. The latest Model aircraft flying ‘Rules’ are set out in the SAMAA Procedures (MOP’s) , [www.samaa.co.za](http://www.samaa.co.za). Claiming not to know or having read these documents is not an acceptable excuse in Law.
2. Included in SAMAA Operating Procedures.
3. Should be displayed at Club, but if not contact the Club secretary.
4. If answer is No, you fail, these should be posted as 3 above. You should not be flying if you don’t know the Rules.
5. Not over pits, club house, parking area or any other area where persons are present.
6. Civil Aviation Authority (CAA) is the legal and Controlling Body for airspace in the RSA.
7. SAMAA and its Members are affiliated to the Aero Club of South Africa (Recreational flying).
8. To fly legally, you need to be a member of a registered club and the Association..
9. At any SAMAA Registered field/Club. There are approx. 220 Registered clubs in the RSA
10. Yes, if you are flying a model weighing in excess of 25 Kg you need a “Permit to fly”
11. Have a standard, transmitter impound, assemble and check model, range check, runway choice.
12. Suggest you introduce yourself to a Committee member, who will follow the club procedure.
13. Model checks, should include control surfaces, linkages, flying surfaces, receiver battery voltage.
14. Essential with the old 35 Mhz system to ensure no interference, If peg on your spot find owner.
15. May not fly as frequency is illegal in the RSA
16. Suggest you borrow one, if challenged re SAMAA membership, you need someone to vouch for you.
17. DO NOT FLY, See if you can find a compatible charger.
18. You should have a voltmeter, or equivalent receiver voltage checker, if not borrow one.
19. Good practice is to do range check before first flight of each day at field.
20. The latest CAA Ruling is that a spotter will be in attendance whenever a pilot is flying, for early warning should a full size aircraft overfly
21. All registered Model aircraft field are limited to 400 feet AGL, Slope and park fly field to 150 feet.
22. Keep clear of Full sized manned aircraft AT ALL TIMES----NON NEGOTIABLE
23. There is always a danger associated with rotating machinery, could throw a blade, or catch clothing.
24. For Safety reasons.
25. Clear off runway, and let others take off
26. If it won’t turn, land it, and bear the consequences. Flying into the pits or spectators is a No.
27. The circuit direction is defined by taking off into wind and then turning away from no fly zone/club.
28. The Safety officer should normally nominate the runway nearest into wind.
29. Report it to the Safety officer and fill in an incident report, if a person is injured, an Accident report
30. Most clubs provide pilot blocks behind a safety net, approx 7m back from runway in use.
31. Go around until runway is clear
32. In all cases of doubt abort, rectify the problem and start again
33. Dead-stick takes precedent, committed to a landing is considered the next priority
34. Try to ensure that the flying taking place is done safely and follows rules.
35. No child should be in the pits—remove same
36. Ask nicely and if ignored, give the offender a written warning with copy to the Club Committee
37. See club rules for Safety officer
38. Fail safe is a safety feature on most receivers, it needs to be set to bring engine to idle, if signal lost.
39. Lithium batteries are dangerous if shorted, due to their high discharge capabilities, potential fire hazard.
40. Electric motors have a high starting torque, and sharp propellers, serious cuts and accidents can occur.
41. Electric motors must only be connected to batteries at the flight line, immediately before takeoff.
42. Dependent on set up, switching off transmitter prior to disconnection of model motor, could start motor.
43. Transmitter battery check, see meter on box, check receiver batteries with special voltmeter.

44. Check voltage readout on transmitter, and if below manufacturers recommendation don't fly without recharging
45. Land as soon as possible transmitter is not waterproof
46. Land soonest, lightning is dangerous
47. Helicopter flying on main runway will fly in the same circuit as the fixed wing models.
48. Ignore it, the chances are that it won't affect your model.
49. Land as soon as possible or hand over your transmitter to the nearest suitable pilot
50. You have a problem
51. You will have to fly out the tank of fuel.
52. Warn other pilots present; keep up speed if there is a wind and land.

## **7.2 REQUIREMENTS FOR THE SOLO PROFICIENCY TEST**

The Solo Test has some more advanced hovering maneuvers and some basic flying maneuvers. This qualification fulfills the minimum requirement of the SAMAA Insurance to hover and fly a model helicopter without an instructor present.

Although not actually part of the test the pilot will have to be able to climb out and fly away positioning for the flying maneuvers and to do turns to position for the next maneuver etc.

The maneuvers must be flown once during the flight test.  
 The pass mark is an average of 50 %, with no less than 30 % for any individual maneuver.  
 The Judges pass/fail decision is and not open to discussion  
 If a pilot fails the test, he may be re-tested once on that day, if time allows

The Solo Proficiency Test will be arranged and conducted in a formal manner, with a minimum of a Club/MHSA Instructor, a second judge holding a minimum of an Advance Proficiency and the duly signed test papers will be forwarded to SAMAA.

## **7.3 REQUIREMENTS FOR THE ADVANCED PROFICIENCY TEST**

The maneuvers must be flown twice during the flight test.  
 The pass mark is an average of 60 %, with no less than 40 % for any individual maneuver.  
 The Judges pass/fail decision is final and not open to discussion.  
 If a pilot fails the test, he may be re-tested once on that day, if time allows

The Advanced Proficiency Test will be arranged and conducted in a formal manner, with a minimum of two MHSA Instructors and the duly signed test papers will be forwarded to SAMAA.

The Advanced Proficiency qualifies a pilot to become a Club Instructor. When accompanied by a Club Instructor, may test a pupil for Hover and Solo Proficiency. (Club instructor and pilot with Advanced Proficiency)

## **7.4 REQUIREMENTS FOR THE INSTRUCTOR PROFICIENCY TEST**

The helicopter used by the pilot for the Instructor Proficiency Test must have been assembled and set up and tuned by the pilot.

The maneuvers must be flown twice during the flight test.  
 The pass mark is an average of 60 %, with no less than 40% for any individual maneuver.  
 The Judges pass/fail decision if final and not open to discussion.  
 If a pilot fails the test, he may be re-tested once on that day, if time allows

He shall be mature and be respected in the flying fraternity with a thorough understanding of building a helicopter, the setup thereof, safety and training a pupil to fly a helicopter.

The Instructor Proficiency Test will be arranged and conducted in a formal manner, with a minimum of one MHSA Instructor Judge and a MHSA Instructor and the duly signed test papers will be forwarded to SAMAA.

The Instructor Proficiency qualifies a pilot to become a MHSA Instructor and when accompanied by a MHSA Instructor, may test a pupil for Hover, Solo and Advanced Proficiency

## **7.5 REQUIREMENTS FOR A DISPLAY PILOT (SAMAA AND NON-SAMAA SANCTIONED EVENTS)**

A Display Pilots' Rating is also attainable. This is only awarded to Instructor rated Pilots who regularly fly at public displays. Any Pilot who wishes to fly at public displays (non-SAMAA sanctioned) regularly must hold a minimum of an Instructor Proficiency rating. Please ensure that SAMAA permission is obtained for any Display or Flying Event at a non-SAMAA registered site to validate the Insurance cover.

A Scale Display Rating is also attainable with a minimum of a Solo Rating by applying to the MHSA committee.

No Pilot holding a rating less than a Solo Proficiency level should be allowed to fly at any SAMAA sanctioned public display or displays at their own club.

## **7.6 THE JUDGES**

### *Club Instructor*

A person, who in a Club's views, is qualified to assist a beginner to learn to fly and who has passed a MHSA Advanced Proficiency Test. A list of approved Club Instructors should be posted on the Club Notice Board and kept updated.

When accompanied by a second qualified Club Instructor, they may test and award MHSA Hover and Solo Proficiency Ratings. The testing Club Instructors may NOT be the pupil primary instructor.

### *MHSA Instructor*

A Pilot who has satisfactorily obtained his MHSA Instructor Proficiency and who has demonstrated to the MHSA Competition Judges or MHSA Instructor Judges that he has a thorough understanding of building a helicopter, the setup thereof, safety and training a pupil to fly a helicopter.

When accompanied by a second qualified MHSA Instructor or a Club Instructor they may test and award MHSA Hover, Solo and Advanced Proficiency Ratings

### *MHSA Instructor Judge*

After a Pilot has been awarded his MHSA Instructor Proficiency he could apply to the MHSA committee to be appointed as a MHSA Instructor Judge. This application must be in writing, giving his modeling and judging experience. The applicant should meet the following criteria to be considered by the MHSA committee.

- (a) He shall be a fully paid up member of MHSA and SAMAA and be in good standing with regards to payments.
- (b) He shall have a minimum of 5 (Five) years' exposure to model flying.
- (c) He shall have judged at competitions and at national level.
- (d) He shall have judged adequate Advanced Proficiency tests to ensure that he has a good understanding of the MHSA requirements.
- (e) He shall be mature.
- (f) He shall be respected in the flying fraternity.
- (g) He shall be approved and appointed by the MHSA Committee

It must be stated that it is MHSA's decision as to how many Judges they wish to appoint in an area or province.

When accompanied by a second qualified MHSA Instructor Judge or a MHSA Instructor, they may test and award MHSA Hover, Solo, Advanced and Instructor Proficiency Ratings

*MHSA Competition Judges* These are the Judges who judge at the MHSA competitions. They are MHSA approved and have a thorough knowledge and understanding of the competition rules and requirements. These Judges may in some cases not ever have flown any form of model or passed any flying test, but are expert Judges. At an official MHSA Competition or an arranged MHSA Proficiency Testing Day, a panel of these Judges may test and award anyone for Hover, Solo, Advanced and Instructor Proficiency Ratings.

There are “quite a few” helicopter pilots / enthusiasts that have been involved in helicopters in South Africa for a long time and who are well respected for their knowledge, expertise and experience. If any of these people would like to get involved in judging and feel they don't want to go through the long process for becoming an instructor, they should contact the MHSAC Committee for a possible MHSAC Competition Judge position.

## Hovering Square Layout

**HOVER**

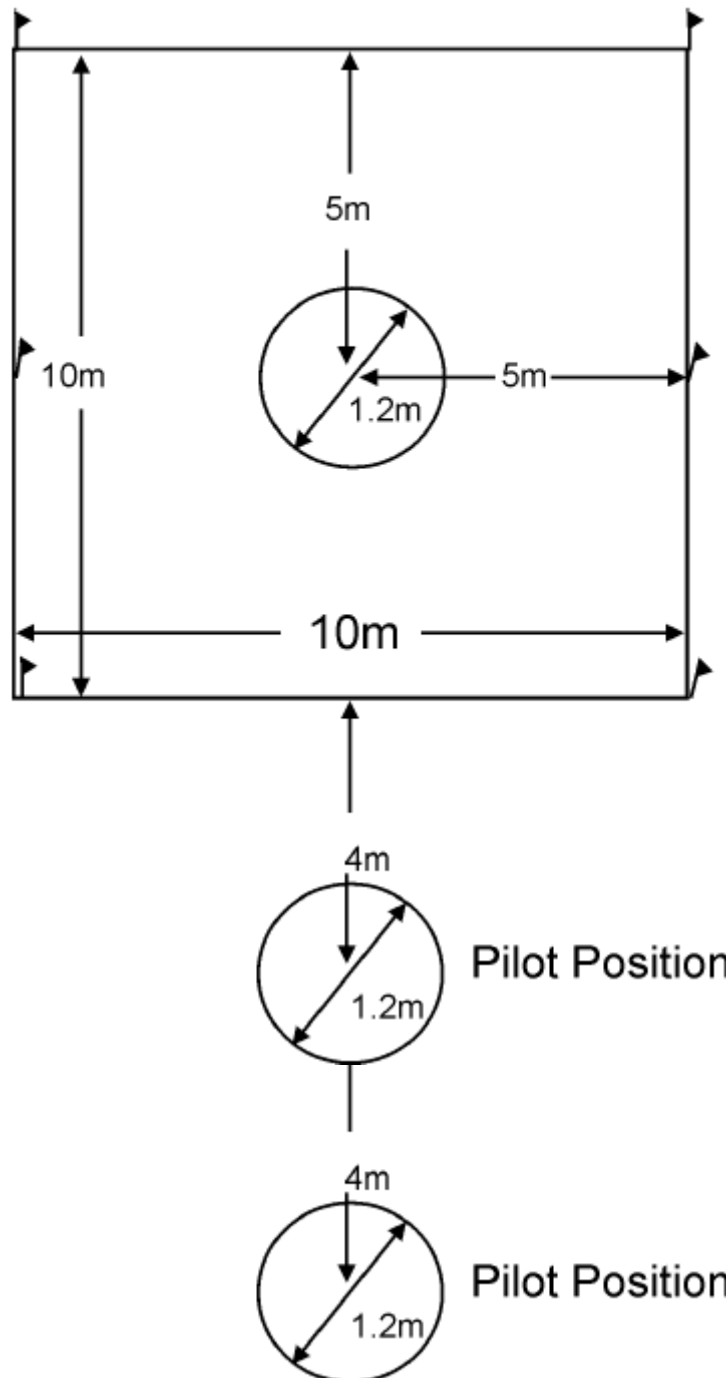

# PROFICIENCY MANOEUVRE DESCRIPTION

**1. Tail-in Vertical Triangle.** Model is positioned tail toward the pilot on the central helipad. (flown or carried) Pilot stands on the 4 metre line on the side of the box closest to the judges. Model takes off from the central helipad, rises vertically to eye level, pauses, hovers sideways with a constant altitude, heading, and speed, either direction, to the edge of the box, pauses, rises 2m in altitude in a straight line diagonally to the central helipad, pauses, descends 2m in altitude in a straight line diagonally to the opposite side of the box, pauses, hovers sideways back to the central helipad, pauses, descends vertically, and lands on the central helipad.

Downgrading Guide: Takeoff, Horizontal hovering lines (2), Diagonal hovering lines (2), Stops (5), Landing, Constant altitude, Constant heading, Constant speed, Positioning.

Tail-in  
Vertical Triangle

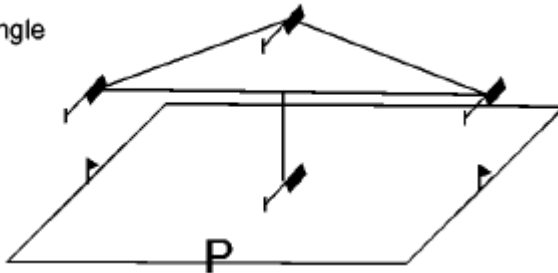

**2. Constant Heading Circle.** Model takes off from the central helipad and rises vertically to eye level, pauses, maintaining constant altitude, heading, and speed, completes a circle to the right or left. The circle passes over the two (2) corner flags opposite the pilot ending over the central helipad, pauses, descends vertically, and lands on the central helipad.

Downgrading Guide: Pilot position, Takeoff, Circle not round, Stops (2), Landing, Constant altitude, Constant heading, Constant speed, Positioning.

Constant Heading  
Circle

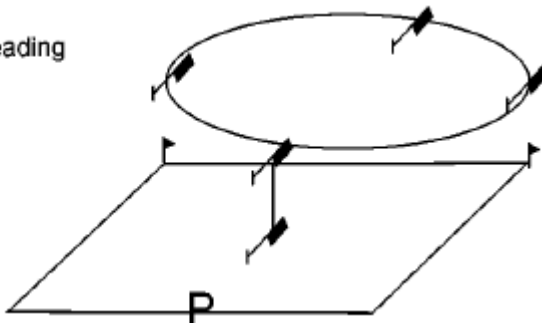

**3. Tail-in Vertical Rectangle.** Model takes off from the central helipad and rises vertically to eye level, pauses, maintaining a constant altitude, heading, and speed, hovers sideways either direction, to the edge of the box, pauses, rises vertically 2m, pauses, hovers sideways over the central helipad to the opposite side of the box, pauses, descends vertically 2m, pauses, hovers back to central helipad, pauses, and descends vertically to the central helipad.

Downgrading Guide: Pilot position, Takeoff, Horizontal lines (3), Vertical lines (2), Stops (6), Landing, Constant altitude, Constant heading, Constant speed, Positioning

Tail-in  
Vertical Rectangle

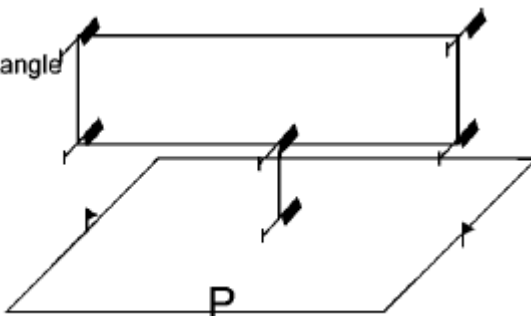

**4. Spike with 90 Degree Pirouettes.** Model takes off vertically from the central helipad and rises vertically to eye level, maintaining constant heading, pauses, rises vertically 2m, pauses, rotates 90 degrees, in either direction, pauses, rotates 90 degrees in the opposite direction, pauses, descends 2m, pauses, descends vertically to the central helipad. Downgrading Guide: Pilot position, Takeoff, Vertical lines (2), Rotation is not 90 degrees (2), Stops (5), Landing, Constant altitude, Constant speed, Positioning.

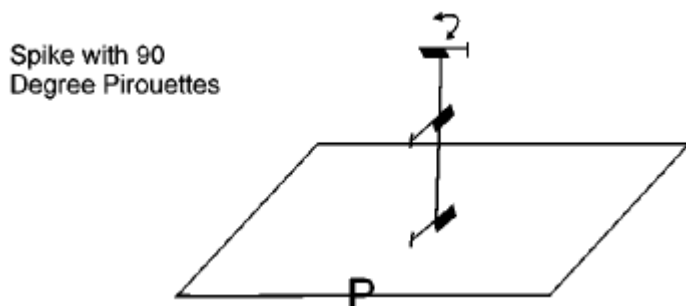

**5. Pass in Review.** Model takes off vertically from the central helipad and rises to eye level, pauses, hovers sideways, either direction, maintaining a constant altitude, heading, and speed, to the edge of the box, pauses, rotates 45 degrees nose into the box, pauses, hovers in a straight line over the central helipad to the opposite side of the box, pauses, rotates 45 degrees in the opposite direction, pauses, hovers sideways back to the central helipad, pauses, descends vertically to the central helipad.

Downgrading Guide: Pilot position, Takeoff, Horizontal lines (3), Stops (6), Model does not maintain 45 degree angle with relation to the box, Landing, Constant altitude, Constant heading, Constant speed, Positioning.

Pass in Review

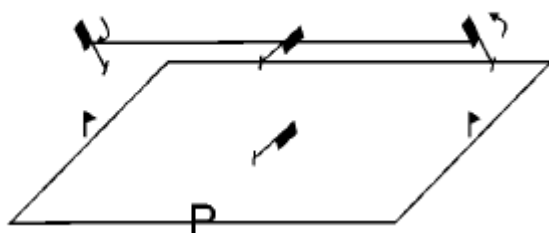

## SOLO PROFICIENCY MANOEUVRE DESCRIPTION

**1. Vertical Triangle.** Model is positioned tail toward the pilot on the central helipad (flown). Pilot stands on the 4m line in front of the judges. Model takes off from the central helipad and rises vertically to eye level, pauses, hovers, either direction, at a constant altitude, heading, and speed, to the edge of the box, pauses, rotates 90 degrees, nose toward the centre of the box, climbs 2m in altitude in a straight line diagonally to the central helipad, pauses, descends 2m back to eye level diagonally in a straight line to the opposite side of the box, pauses, rotates 90 degrees in the opposite direction, hovers to the central helipad, pauses, descends vertically to central helipad.

Downgrading Guide: Pilot position, Takeoff, Horizontal lines (2), Diagonal lines (2), Stops (7), Landing, Constant altitude, Constant heading, Constant speed, Positioning.

Vertical Triangle

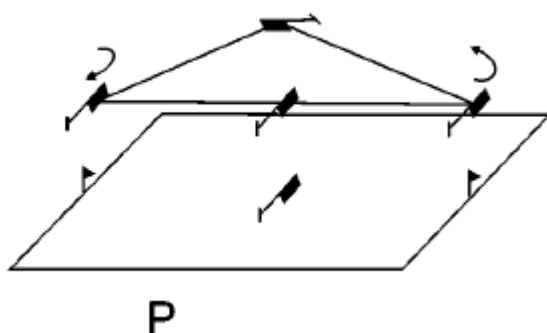

**2. Constant Heading Eight.** Model takes off from the central helipad and rises vertically to eye level, pauses, begins a forward hovering circle, maintaining a constant altitude, heading, and speed, in either direction. The circle passes over

the two (2) corner flags on one side of the box and back to the central helipad, continues and makes another circle in the opposite direction to the central helipad, pauses, descends vertically to the central helipad.

Downgrading Guide: Pilot position, Takeoff, Circles not round (2), Stops (2), Landing, Constant attitude, Constant heading, Constant speed, Positioning.

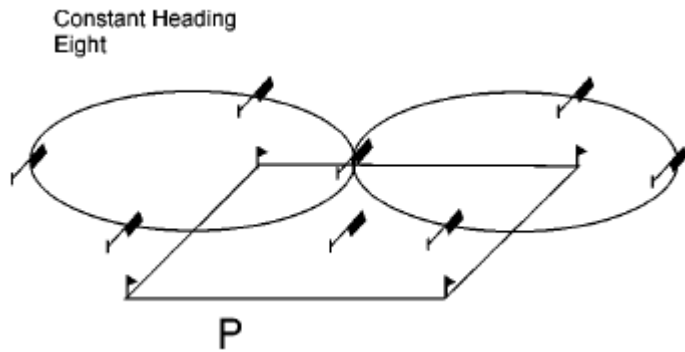

**3. Spike with 90 and 180 Degree Pirouettes.** Model takes off from the central helipad and rises vertically to eye level, pauses, rotates 90 degrees in either direction, pauses, climbs vertically 2m, pauses, rotates 180 degrees in the opposite direction, pauses, descends vertically 2m, pauses, rotates 90 degree in the original direction, pauses, descends vertically to central helipad.

Downgrading Guide: Pilot position, Takeoff, Rotations not 90 degrees (2), Vertical lines (2), Rotation not 180 degrees (1), Stops (6), Landing, Constant altitude, Constant heading, Constant speed, Positioning.

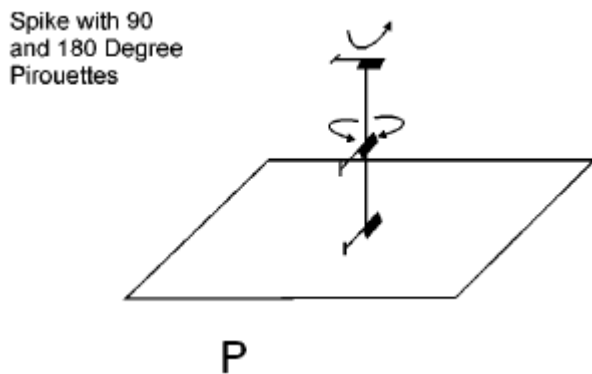

**4. Straight and Level Flight.** The model takes off from the helipad and climbs away, gaining speed and altitude in the direction of the circuit pattern, either left or right. At a distance greater than 30m the helicopter is turned and flown straight and level past the pilot. At a distance of greater than 30m on the other side the pilot performs a turn and the helicopter is again flown straight and level past the pilot (in the opposite direction). The turn is at the pilot's discretion, it may be a level turn, a stall turn or anything in between.

Downgrade Guide: Pilot position, speed control, height control, directional control, control and smoothness of turn.

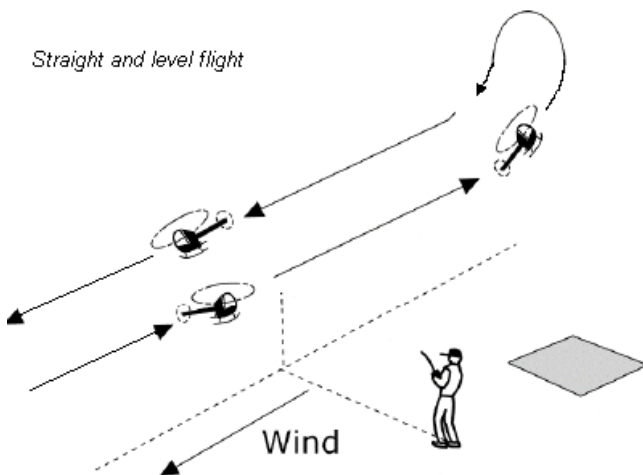

**5. Figure 8.** The model moves away at its chosen height for a distance of about fifteen meters, turn away from the pilot, continue turn through more than 180 deg and bringing the model back across in front of the central helipad, continues at



the same speed in this direction until it has flown past the pilot for a further fifteen meters to his opposite side, turn away from the pilot again, continue turn through more than 180 deg and bring the model across in front of the central helipad, now moving in the same direction as the first leg. The turns should be made by use of cyclic and rudder coordinated correctly, and must not be half pirouettes at the end of each leg  
 Downgrade Guide: Pilot position, height control, speed control, smoothness of turns, straight legs.

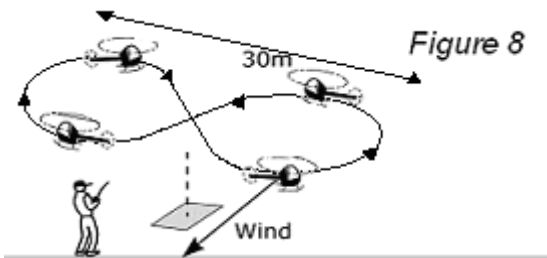

**6. Cobra Vee.** Model flies straight and level for 10m, climbs at a smoothly-rounded curve of 45 degrees, flies straight a minimum of 10 meters, pushes over 90 degrees to descend at a 45 degree angle, flies straight a minimum of 10 meters, recovers in a smoothly-rounded curve, same as first part of manoeuvre, to level flight, flies straight and level for 10 meters at original altitude. Manoeuvre should be centred on the midline.

Downgrading Guide: Pilot position, Entry line, Climb is more or less than 45 degrees, Pushover is more or less than 90 degrees, Pullout is more or less than 45 degrees, Exit line, Manoeuvre is not in a vertical plane, Positioning.

Cobra Vee



**7. Approach and Go Around (downwind).** At an altitude of no less than 10m and on a heading parallel to the flight line, the helicopter begins a constant rate descent and deceleration to be stopped above the central helipad, pause, climb and accelerate to a height of no less than 10m. The descent and climb paths should be approximately 45 deg and symmetrical to each other. This manoeuvre must be done in the opposite direction to manoeuvre 8. This is to demonstrate approaches from both sides.

Downgrading Guide: Pilot position, Entry line, Descent or climb is not smooth or at a constant angle, Descent and climb not symmetrical, Heading is not constant or parallel to the Flightline, Unsteady hovers, Hover not over the central helipad.

Approach and Go Around (down wind)

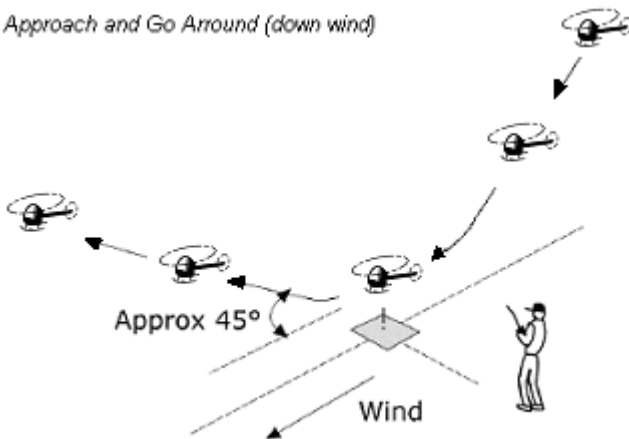

**8. Approach and Landing (into wind).** At an altitude of no less than 10m and on a heading parallel to the flight line and opposite to manoeuvre 7, the helicopter begins a constant rate descent to a landing on the central helipad. If the skids are completely inside the central helipad, a maximum of 10 points can be earned. If the skids are on the circle of the central helipad, a maximum of 9 points can be earned. If the skids are inside the box, a maximum of 8 points can be earned. If the skids are on or outside the box, a maximum of 5 points may be earned. The pilot may hover for a short time before touch down. The helicopter may be turned into wind or into the tail in position before touch down. Downgrading Guide: Pilot position, Descent is not smooth or at a constant angle, Landing is not on the central helipad, Heading is not constant or parallel to the Flight line, Model hovers excessively prior to Landing, Landing is rough., landing outside central helipad.

*Approach and Landing (into wind)*

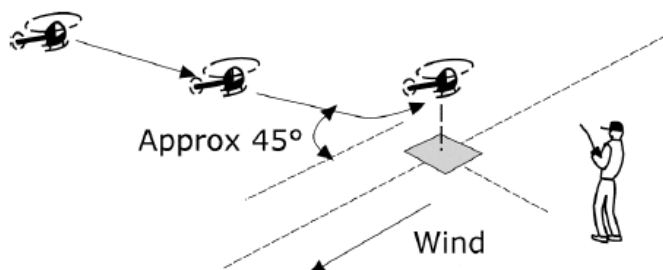

## ADVANCED PROFICIENCY MANOEUVRE DESCRIPTION

**1. Vertical Triangle with 180 Degree Pirouettes.** Model is positioned on central helipad parallel to judges. Model takes off from the central helipad and rises to eye level, pauses, hovers backward to the edge of the box at a constant altitude, heading, and speed, pauses, rotates 180 degrees in either direction, pauses, climbs 5m in altitude in a straight line backward at a 45 degree angle to the central helipad, pauses, descends 5m to original altitude in a straight line backward at a 45 degree angle to the opposite side of the box, pauses, rotates 180 degrees in the opposite direction, pauses, hovers backward to the central helipad, pauses, descends vertically to central helipad. Downgrading Guide: Pilot position, Takeoff, Rotations are more or less than 180 degrees, Horizontal lines (2), Diagonal lines (2), Stops (7), Landing, Positioning, If the second rotation is not in the opposite direction from the first, a score of zero (0) shall be awarded.

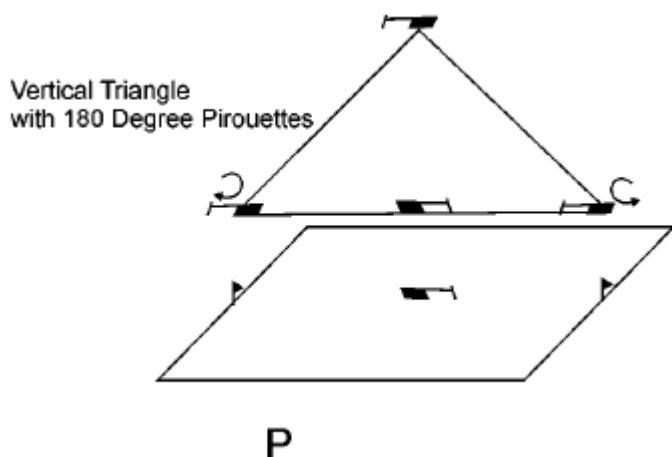

**2. Nose-in Circle.** Model takes off from the central helipad and rises vertically to eye level, pauses, hovers backward in a straight line, at a constant altitude, heading, and speed to edge of box, pauses, hovers either direction with nose pointing at the central helipad in a 5m radius circle passing over the centre of each side of the box, pauses, hovers forward in a straight line to the central helipad, pauses, descends vertically to central helipad. Downgrading Guide: Pilot position, Takeoff, Horizontal lines (2), Stops (4), Circle is not round, Constant altitude, Constant heading, Constant speed, Landing, Positioning.

### Nose in Circle

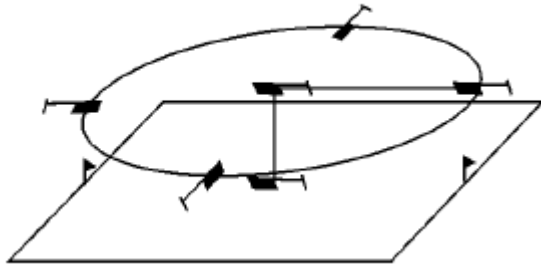

**3. Vertical Rectangle with 360 Degree Pirouettes.** Model takes off from the central helipad and rises vertically to eye level, pauses, hovers backward in a straight line at a constant altitude, heading, and speed, to the edge of the box, pauses, climbs vertically 2m, pauses, rotates 360 degrees in either direction, pauses, climbs vertically 2m, pauses, hovers forward in a straight line over the central helipad to the opposite side of the box, pauses, descends vertically 2m, pauses, rotates 360 degrees in the opposite direction, pauses, descends vertically 2m, pauses, hovers backward in a straight line to the central helipad, pauses, descends vertically to central helipad.

Downgrading Guide: Pilot positioning, Takeoff, Horizontal lines (3), Vertical lines (4), Rotations more or less than 360 degrees, Stops (10), Landing, Constant altitude, Constant heading, Constant speed, Positioning, If the second rotation is not in the opposite direction from the first, a score of zero (0) shall be awarded.

### Vertical Rectangle with 360 Degree Pirouettes

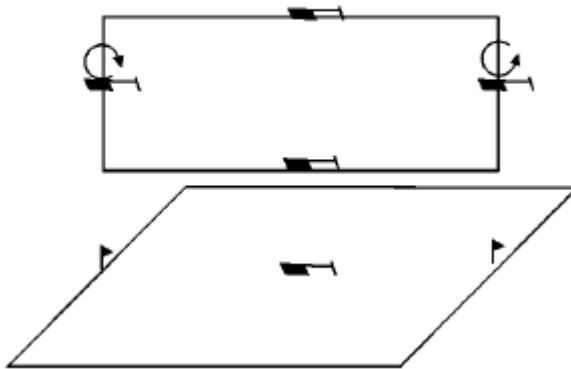

**4. 540 Degree Stall Turn.** Model flies straight and level for 10m then climbs with a smoothly- rounded curve of 90 degrees to a vertical climb. When the vertical climb stops, the model rotates 540 degrees about the yaw axis so that the nose points downward. While diving, the model follows the same path as the beginning of the manoeuvre. Entry and exit should be at the same altitude. The beginning and end of the pull ups should be on the midline and the vertical line offset in the direction of flight.

Downgrading Guide: Pilot position, Entry line, Climb and descent paths are different, End of climb is not vertical, Rotation begins before or after end of climb, Rotation is more or less than 540 degrees, Drift occurs during the climb or descent, Exit line, Positioning.

### 540 Degree Stall Turn

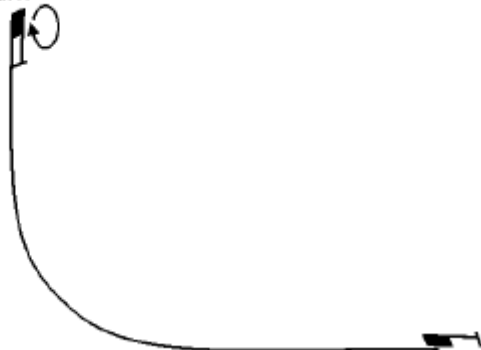

**5. Slow Roll.** Model flies straight and level for a minimum of 10m, rolls through one (1) complete 360 degree revolution maintaining the nose in the direction of flight, flies straight and level for the same duration and at the same altitude as the entry. Manoeuvre is centred with the model inverted at the midline and the roll portion of the manoeuvre should have a duration of 3 seconds minimum.

Downgrading Guide: Pilot position, Less than 3 seconds, Changes in altitude, Changes in heading, Roll is more or less than 360 degrees, Roll rate is not constant, Positioning.

Slow Roll



**6. Immelmann S.** Model flies straight and level, executes a half-loop, flies level 5m minimum, rolls 360 degrees from inverted to inverted, flies level 5m minimum, executes a half-loop back to original altitude and flies straight and level. Manoeuvre begins and ends with level flight on the midline.

Downgrading Guide: Entry half-loops are not constant radius, Half-loops are not in a vertical plane, No level flight between half-loop and roll (2), Roll is not 360 degrees, Roll changes heading, Roll changes altitude, Roll rate is not constant, Positioning.

Immelman S



**7. Stall Turn with Half-Roll.** Model flies straight and level for 10m, climbs vertically with a smoothly rounded curve, stops, rotates 180 degrees so the nose is downward, executes half-roll, either direction, and recovers to straight level flight 10m at original altitude. Note: there should be a helicopter length of straight flight between the rotation and the half-roll, and between the half-roll and the recovery. Vertical line should be on the midline.

Downgrading Guide: Entry end of climb is not vertical, Rotation is before the end of climb, Drift occurs during the climb, rotation, or Descent, Heading changes during roll, Entry and exit altitude are not the same, Positioning.

Stall Turn  
with 1/2 Roll

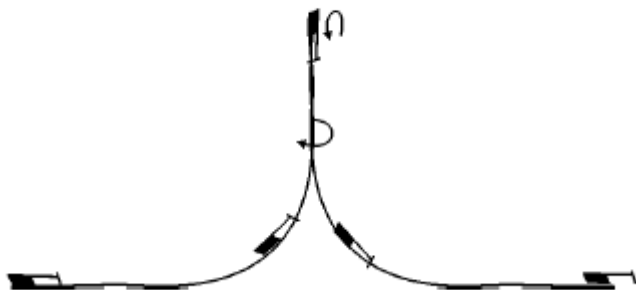

**8. Auto Rotation with 180 Degree Turn.** Model flies at a minimum altitude of 20m with a speed that is less than required for stationary flight. The engine must be stopped before the model crosses the midline and begins a 180 degree turn to land on the central helipad. Manoeuvre begins at the midline. If the skids are inside the central helipad, a maximum of 10 points can be earned. If the skids touch the central helipad, a maximum of 9 points can be earned. If the skids are outside the central helipad, a maximum of 8 points can be earned. If the skids are on or outside the box, a maximum of 5 points can be earned. If the motor is running after the model crosses the centreline, a score of zero (0) shall be given.

Downgrading Guide: Turn not 180 degrees, Turn not constant rate, Model lands with forward speed, Model lands roughly, Final position is not parallel to the flight line.

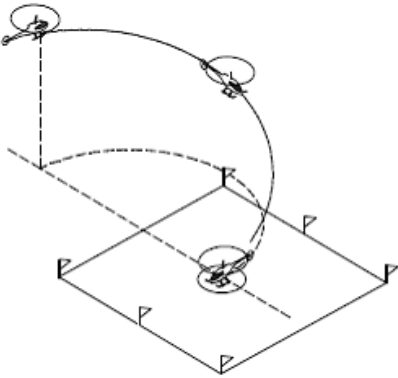

*Autorotation with 180 Degree turn*

## **INSTRUCTOR PROFICIENCY TEST DESCRIPTION**

THE TEST USED FOR THE INSTRUCTOR PROFICIENCY IS THE CURRENT OR TWO PREVIOUS F3C SCHEDULES, EITHER P OR F SCHEDULE AND IS AVAILABLE FROM THE FAI WEBSITE. The pilot is to provide the test Instructor Judges/Instructor with the relevant schedule/maneuvers for the test.



# Helicopter Hover Proficiency Test Sheet



MANOEUVRE	Judge 1	Judge 2
1. Oral Test – Eight Questions regarding safety    Pass or Fail		
2. Pre-Flight Checks, Freq. Control, Club Rules    Pass or Fail		
3. Tail In Vertical Triangle		
4. Constant Heading Circle		
5. Tail In Vertical Rectangle		
6. Spike with 90 Degree Pirouettes		
7. Pass in Review		
<b>Minimum Score per Manoeuvre</b>	<b>3</b>	<b>3</b>
<b>SCORE SUB TOTALS</b>		
<b>SCORE FOR EACH FLIGHT (out of 50)</b>		
<b>PERCENTAGE</b>		
<b>AVE % OF BOTH FLIGHTS</b>		
<b>PASS MARK</b>	<b>50 %</b>	
<b>N.B. If less than the minimum score is achieved for any manoeuvre, the test will be deemed a failure.</b>		
<b>Please print the following</b>		
Pilot's Name:	Club Name:	
Pilot's Address:	Date:	
	Tel No.(W):	
	Cell No.:	
Pilot's signature:	SAMAA No.:	
Judges Names 1 :	Signature:	
2 :	Signature:	
Club Chairman :	Signature:	



# Helicopter Solo Proficiency Test Sheet



MANOEUVRE	Judge 1	Judge 2
1. Vertical Triangle		
2. Constant Heading Eight		
3. Spike with 90 and 180 Deg. Pirouettes		
4. Straight and Level flight with own turn		
5. Figure 8		
6. Cobra Vee		
7. Approach and go around (downwind)		
8. Approach and Landing (into wind)		
<b>Minimum Score per Manoeuvre</b>	<b>3</b>	<b>3</b>
<b>SCORE SUB TOTALS</b>		
<b>SCORE FOR EACH FLIGHT (out of 80)</b>		
<b>PERCENTAGE</b>		
<b>AVE % OF BOTH FLIGHTS</b>		
<b>PASS MARK</b>	<b>50 %</b>	
<b>N.B. If less than the minimum score is achieved for any manoeuvre, the test will be deemed a failure.</b>		
<b>Please print the following</b>		
Pilot's Name:	Club Name:	
Pilot's Address:	Date:	
	Tel No.(W):	
	Cell No.:	
Pilot's signature:	SAMAA No.:	
Judges Names 1 :	Signature:	
2 :	Signature:	
Club Chairman :	Signature:	



# Helicopter Advanced Proficiency Test Sheet



MANOEUVRE	First Flight		Second Flight	
	Judge 1	Judge 2	Judge 1	Judge 2
1. Vertical Triangle with 180 Deg. Pirouettes				
2. Nose In Circle				
3. Vertical Rectangle with 360 Deg. Pirouettes				
4. 540 Degree Stall Turn				
5. Slow Roll				
6. Immelmann S				
7. Stall Turn with 1/2 Roll				
8. Autorotation with 180 Degree Turn				
<b>Minimum Score per Manoeuvre</b>	<b>4</b>	<b>4</b>	<b>4</b>	<b>4</b>
<b>SCORE SUB TOTALS</b>				
<b>SCORE FOR EACH FLIGHT (out of 80)</b>				
<b>PERCENTAGE</b>				
<b>AVE % OF BOTH FLIGHTS</b>				
<b>PASS MARK</b>	<b>60 %</b>			
<b>N.B. If less than the minimum score is achieved for any manoeuvre, the test will be deemed a failure.</b>				
<b>Please print the following</b>				
Pilot's Name:	Club Name:			
Pilot's Address:	Date:			
	Tel No.(W):			
	Cell No.:			
Pilot's signature:	SAMAA No.:			
Judges Names 1 :	Signature:			
2 :	Signature:			
Club Chairman :	Signature:			





# Helicopter Instructor Proficiency Test Sheet



MANOEUVRE	First Flight		Second Flight	
	Judge 1	Judge 2	Judge 1	Judge 2
1				
2.				
3.				
4.				
5.				
6.				
7.				
8.				
9.				
10.				
<b>Minimum Score per Manoeuvre</b>	<b>4</b>	<b>4</b>	<b>4</b>	<b>4</b>
<b>SCORE SUB TOTALS</b>				
<b>SCORE FOR EACH FLIGHT (out of 100)</b>				
<b>PERCENTAGE</b>				
<b>AVE % OF BOTH FLIGHTS</b>				
<b>PASS MARK</b>	<b>60 %</b>			
<b>N.B. If less than the minimum score is achieved for any manoeuvre, the test will be deemed a failure.</b>				
<b>Please print the following</b>				
Pilot's Name:	Club Name:			
Pilot's Address:	Date:			
	Tel No.(W):			
	Cell No.:			
Pilot's signature:	SAMAA No.:			
Judges Names 1 :	Signature:			
2 :	Signature:			
Club Chairman :	Signature:			

# SECTION 8

## THE PROFICIENCY TESTS --- MULTIROTOR MODELS

The primary purpose of proficiency testing is to improve the skill level of the pilot. This applies equally to a newcomer who is learning to hover and to an advanced pilot perfecting aerobatics.

The tests proposed have been split into three classes. Solo Proficiency, Advanced Proficiency and Instructor Proficiency. An Advanced test may not be done unless a SOLO test has been completed previously.

During the normal learning process of a multirotor pilot, the initial challenge is to learn to hover, without using the GPS. The pilot needs to practice hovering and the hover maneuver skills for a fairly lengthy period before moving onto forward flight and flying maneuvers.

### **The Model**

The test can be performed with virtually any multirotor model.

Whatever model is brought by the pilot, it must be suitable to fly the manoeuvres required by the test.

The Judges do not have the authority to alter the required manoeuvres to suit a model and **if, in the judges opinion, the model is unsuitable for the test, then it should be explained to the pilot that the model available is unsuitable for the test..** The supply of the model to do the test is the responsibility of the pilot and it is pilots ability that is being testing, not the model.

Electric Powered Models must be treated as LIVE as soon as the main flight battery is connected, irrespective of radio state and great care must be demonstrated by the pilot. The arming sequence should be clearly understood by the pilot and this fact must be demonstrated to the judges by the pilot.

### **Multi-Rotor types**

Multirotors come in numerous variations, sizes and formats, not all of which will be suitable for the multirotor tests.

Some of the many multirotor models available are listed below;

**Bi-rotor ---**These have two motors only and two servos. Each motor is mounted on a servo controlled pivot. These are the least stable of the multirotors and are therefore not recommended to use for the tests.

**Tri-rotor / Tricopter--** As the name suggests these have 3 motors, typically spaced in a Y-shape, with the rear single motor being mounted on a servo controlled pivot.

**Quad-rotor / Quadcopter --** These are likely to be the most common model used, using four fixed motors. (This excludes variable pitch models mentioned further down this list) They can be safely flown in either a plus or cross format, this will boil down to what the individual pilot feels is easier to orientate and no preference should be given to either. There will be two motors spinning clockwise and two counter clockwise to overcome the torque effect. By slowing a pair of motors down and speeding up the other pair, the torque effect is used for yaw.

**Hex-rotor / Hexacopter --**With six motors, these can either have the motors spaced out evenly in a circle or doubled up in a Y-format. Again no servos are used for this format. Hex-rotors offer no more stability than a quad, but, **if fitted with firmware specific**, do offer an ability to keep flying in the event of a certain motor failures. These will have three motors spinning clockwise and three counter clockwise, when set up as a Y-shape, there will be one motor of each direction on each arm.

**Octo-rotor / Octacopter --**As per the hex-rotor, these can be set up with all motors in a circle, or set up with double motors as per the plus or cross quad-rotors. As with hex-rotors these offer more resistance to motor failures. These will have four motors spinning clockwise and four counter clockwise. When set up as a quad-rotor format there will be one motor of each direction on each arm.

**Variable Pitch Multirotors --**These can be any format from above, but are most typically done as quad-rotors as this tends to be the best balance between size and aerobatic performance. In the quad-rotor format a single motor drives four variable pitch rotors, which are intern controlled by servos. This variable pitch approach allows for a motor idle up to be set and sustained inverted flight to be achieved.

**Reverse Direction Multirotors --**Another recent development has seen multirotors with reversible speed controllers / motors, this allows for sustained inverted flight as the motors reverse when inverted.

### **All multi-rotor proficiencies tests are to be done with NON-GPS assisted mode models.**

#### **Gyros, Electronic Stabilisation and GPS.**

The use of an electro-mechanical or solid state gyro/s in a multirotor being used to take the test is acceptable, although electronic stabilisation, **which is inherent in all control units**, is restricted to enabling flight. **at no point should the stabilisation effect take over control from the pilot or achieve automated (or self-levelled) flight.**

This allows a range of gyros to be fitted, from simple yaw dampers to solid state heading lock units.

**The use of any autopilot and/or artificial stability features which are (or may be) designed into such units beyond definition above is not acceptable during the test and are not allowed.**

Pilots should be prepared to explain the capabilities of the system they are using and show that it does not take over

control from the pilot and that automated flight will not be achieved during the test.  
GPS must not be used during the test.

## THE PROFICIENCY TEST

**The Proficiency test is made up of three sections, all sections are equally important and a lack of knowledge in any one section will require a retest. The sections are;**

1. ORAL; The pilot must answer a minimum of eight questions on Safety matters from the SAMAA and MHSA Safety Codes and local flying rules. Please note that questions 1 to 5 are compulsory, and that any pilot not knowing the answers to these questions will automatically fail.

A pilot who has done a flying test which was found to be only just acceptable and who lacks knowledge on the questions, should be asked more than eight questions and if the judges are still not satisfied that the pilot has actually read the safety codes, **you should not hesitate to fail him.**

The proficiency scheme is a test of both flying ability and knowledge

2. PRE FLIGHT INSPECTION;

The pilot is to go through his preflight checks as if the test was his first flight of the day.

Points the judges should look for are that the pilot has a steady and regular ground routine and is in full control of what he is doing whilst preparing the multicopter for flight.

Electric powered models must be carried out from the pits area to a safe point before the flight battery is connected and the model MUST be considered live as soon as the flight battery is plugged in. Great care should be taken at this point and any help given to the pilot should be in the interests of safety.

A poor performance in this section is not direct grounds for failing the candidate but must certainly be part of a cumulative fail if other aspects of his performance is below the standard required.

3. FLYING THE TEST;

### General Manoeuvres and Hovering

There is no requirement for the fixed positioning of manoeuvres relative to the wind direction in the Multirotor test. (except, obviously landing into wind)

The pilot must ensure that the model stays at a reasonably constant height and heading and moves at a constant speed through the manoeuvres as required. All deviations from steady and well controlled flight should be noted as they will form part of your examiner's judgement of the test flight. Good use of the controls to maintain a constant height throughout the test is something both the judges and the pilot must watch carefully.

All take-offs and landings should be smooth, without undue oscillations, and lifts and descents should be straight and controlled with the model a comfortable and safe distance in front of the pilot. In any stationary hovering the model should remain steady and should not oscillate unduly.

Movement of the model from one point to another whilst in the hover should be done at a steady walking pace.

The standard 'brief' hover time should be about five seconds. The judge should discuss this with the pilot before the test clearly stating that he wants to see a positive stop with the hover long enough to show that the model is well controlled and steady with little wandering or oscillation. Stopwatch accuracy is not required.

The pilot should also be aware that the onus is on him to commence with the next manoeuvre. However, the pilot may ask the Instructor to indicate when he is satisfied that previous manoeuvre has been completed, to help him to decide when to move on. This is quite permissible if requested by the pilot.

## 8.1 REQUIREMENTS FOR THE "SOLO" PROFICIENCY TEST

The "SOLO" Proficiency Test consists of an oral test, a pre-flight inspection and a basic flying test.

This qualification fulfills the minimum requirement of the SAMAA Insurance to fly a model multicopter at a Club field without an instructor present.

**Solo proficiency does** not authorize the pilot to fly his multirotor model **from** the Club field runway, when general flying is in progress.

Learning to hover and fly has always been at club level. The SOLO Proficiency Test is the first step for the local club pilot to achieve independence.

The Club Instructors position is critical to the development of the flying expertise of members in the club

The first two test items, Oral (general and safety) and Pre-flight, will require some homework from the pilot, the third item, the flying test needs to be flown **once during the proficiency test.**

Each maneuver is marked out of 10.

The pass mark is an average of 50 %, with no less than 3 out of 10 for any individual maneuver.

Do remember failing the ORAL. Means that you fail the Test.

The Judges pass/fail decision is final and not open to discussion.

If a pilot fails the test, he may be re-tested once on the same day, if time allows.

The Solo Proficiency Test will be arranged and conducted in a formal manner, with a minimum of two qualified multirotor Advanced pilots, or with one Advanced Proficiency pilot and one multirotor Instructor, the duly completed and signed test papers must be forwarded to SAMAA.

Copies of questions for the oral section of the proficiency test will be found under the Helicopter hover proficiency. Section 7 Item 7.1

## **8.2 REQUIREMENTS FOR THE “ADVANCED” PROFICIENCY TEST**

The maneuvers must be flown twice during the flight test.

The multicopter model must have been assembled and set up and trimmed by the pilot, before the test.

The pass mark is an average of 60 %, with no less than 4 for any individual maneuver.

The Judges pass/fail decision is final and not open to discussion.

If a pilot fails the test, he may be re-tested once on that day, if time allows

The Advanced Proficiency Test will be arranged and conducted in a formal manner, with a minimum of two Multicopter Instructors present and the duly signed test papers will be forwarded to SAMAA.

The Advanced Proficiency qualifies a pilot to become a Club Instructor, and teach members to fly.

The teaching of pupils to fly a multirotor model, when requested is essential to the future of the group.

## **8.3 REQUIREMENTS FOR THE “INSTRUCTOR” PROFICIENCY TEST**

No test is required for a Instructor Proficiency Qualification Test. Qualification is by written application as set out in this section 8.5 under “Multirotor Instructor.”

## **8.4 REQUIREMENTS FOR A DISPLAY PILOT**

A Display Pilots’ Rating is attainable. This will only awarded to Instructor rated Pilots who wish to fly regularly at Public displays. Any Pilot who wishes to fly at public displays regularly must hold a minimum of an Instructor Proficiency rating, and have received the rating of Display pilot from the MHSA committee Ensure that SAMAA permission is obtained for any pilot to fly at any Display or Flying Event at a non-SAMAA registered site to validate the Insurance cover.

A Pilot holding a Solo Proficiency level is permitted to fly at any display held at his own club, if under supervision.

## **8.5 THE JUDGES**

As a judge, the level of competence you should expect of a pilot, before awarding a solo, should be based on the criterion; is that person, in your **opinion, capable and competent to be allowed to fly on a club field unsupervised?**

### *Club Instructor*

A person, who in a Club’s views, is qualified to assist a beginner to learn to fly and who has passed a Multirotor Advanced Proficiency Test.

When accompanied by a second qualified Multirotor Instructor pilot, he may test and award Multirotor Solo Proficiency Ratings. The testing Club Instructor or Multirotor Advanced pilot may NOT be the pupils primary teaching instructor.

### *Multirotor Instructor*

A Pilot who has satisfactorily obtained his Multirotor Advanced Proficiency and who has demonstrated to the MHSA Competition Judges or MHSA Instructor Judges that he has a thorough understanding of building and setting up a multirotor model, and has an interest in training a pupil to fly a multirotor model, may apply to the MHSA committee to be appointed as a Multirotor Instructor. This application must be in writing, giving his modeling and judging experience. The applicant should meet the following criteria to be considered by the MHSA committee.

a.) He shall be a fully paid up member of MHSA and SAMAA and be in good standing with regards to payments.

b.) He shall have a minimum of 5 (Five) years’ exposure to model flying. and should have at least achieved a SAMAA fixed wing or Heli, Gold or Advanced

- proficiency level. and have achieved at least 70% in the Advanced Multirotor Test.
- c.) He Should have knowledge of how to set up auto-pilot systems, and have a understanding of the Multirotor requirements
  - d.) Should have knowledge on how to setup BUDDY BOX system on multirotor system.
  - e.) He shall be mature.
  - f.) He shall be respected in the flying fraternity.
  - g.) He should be willing to train a pupil to fly a multirotor model.

On receipt the pilots Application shall be submitted for Approval to the MHSA Committee

It must be stated that it is MHSA's decision as to how many Istructors they wish to appoint in an area or province.

When accompanied by a second qualified Multirotor Instructor or a Club Instructor as described above, he may test and award Multirotor Solo and multirotor Advanced Proficiency Ratings.

## **MULTIROTOR "SOLO" PROFICIENCY MANOEUVRE DESCRIPTION**

**ALL MANOEUVERS FOR MULTIROTOR "SOLO" TESTS ARE AS PER HELICOPTER MANOEUVERS SET OUT IN SECTION 7 UNDER HELICOPTER PROFICIENCY TESTS.**

**EXCEPT THAT UNDER THE VERTICAL TRIANGLE MANOEUVRE THE TRIANGLE IS TURNED UPSIDE DOWN SO AS TO GIVE A HORIZONTAL FLIGHT OF SOME 30 METERS AT THE TOP.**

## **MULTIROTOR "ADVANCED" PROFICIENCY MANOEUVRE DESCRIPTION**

**THE MANOEUVERS, EXCEPT FOR MANOEUVERS NO'S 124&6 WHICH ARE AS PER HELICOPTER DESCRIPTIONS IN CHAPTER 7, NEED TO BE DEMONSTRATED TO THE PILOT BY AN INSTRUCTOR, TO ENSURE THAT THE CORRECT MANOEUVERS ARE PERFORMED AT THE TEST.**

## **MULTIROTOR "INSTRUCTOR" PROFICIENCY MANOEUVRE DESCRIPTION**

**NO FLYING TEST, OVER AND ABOVE THE ADVANCED PROFICIENCY IS REQUIRED, TO QUALIFY FOR THE INSTRUCTORS BADGE, THE INFORMATION REQUESTED IN POINT 8.4 "JUDGES" IS TO BE SUBMITTED AND ACCEPTED, BY THE MHSA COMMITTEE.**



# Multicopter Solo Proficiency Test Sheet



MANOEUVRE	Judge 1	Judge 2
1. Oral Test –eight questions regarding Safety [ PASS OR FAIL]		
2. Pre-flight checks, Frequency control, Club Rules [ PASS OR FAIL]		
3. Tail in Vertical Triangle ( apex at bottom)		
4. Constant Heading Circle		
5. Tail in Vertical Rectangle		
6. Spike with 90 degree pirouette at top		
7. Straight and Level flight with own turn.		
8. Approach and Landing (into wind)		
<b>Minimum Score per Manoeuvre</b>	<b>3</b>	<b>3</b>
<b>SCORE SUB TOTALS</b>		
<b>SCORE FOR EACH FLIGHT (out of 60)</b>		
<b>PERCENTAGE</b>		
<b>AVE % OF BOTH FLIGHTS</b>		
<b>PASS MARK</b>	<b>50 %</b>	
<b>N.B. If less than the minimum score is achieved for any manoeuvre, the test will be deemed a failure.</b>		
<b>Please print the following</b>		
Pilot's Name:	Club Name:	
Pilot's Address:	Date:	
	Tel No.(W):	
	Cell No.:	
Pilot's signature:	SAMAA No.:	
Judges Names 1 :	Signature:	
2 :	Signature:	
Club Chairman :	Signature:	



# Multicopter Advanced Proficiency Test Sheet



MANOEUVRE	First Flight		Second Flight	
	Judge 1	Judge 2	Judge 1	Judge 2
1. Figure 8 with heading change				
2. Nose In Circle				
3. Nose down (approx 45 Deg) spiral/ hover				
4. 45 Deg Landing Approach, into and Downwind				
5. Stationary FLIP/ROLL				
6. Spike with two 360 Deg Pirouettes				
7. Nose in landing				
8. Spiral/ Emergency Descent to land.				
<b>Minimum Score per Manoeuvre</b>	<b>4</b>	<b>4</b>	<b>4</b>	<b>4</b>
<b>SCORE SUB TOTALS</b>				
<b>SCORE FOR EACH FLIGHT (out of 80)</b>				
<b>PERCENTAGE</b>				
<b>AVE % OF BOTH FLIGHTS</b>				
<b>PASS MARK</b>	<b>60 %</b>			
<b>N.B. If less than the minimum score is achieved for any manoeuvre, the test will be deemed a failure.</b>				
<b>Please print the following</b>				
Pilot's Name:		Club Name:		
Pilot's Address:		Date:		
		Tel No.(W):		
		Cell No.:		
Pilot's signature:		SAMAA No.:		
Judges Names 1 :		Signature:		
2 :		Signature:		
Club Chairman :		Signature:		



# Multicopter Instructor Proficiency Test Sheet



MANOEUVRE	First Flight		Second Flight	
	Judge 1	Judge 2	Judge 1	Judge 2
FOR AN INSTRUCTORS QUALIFICATION				
<b><u>ATTACH TO THIS FORM THE FOLLOWING:</u></b>				
1.) A COPY OF THE PILOTS SIGNED				
“ADVANCED” PROFICIENCY TEST				
2.) A WRITTEN APPLICATION FOR				
“INSTRUCTORS”QUALIFICATION OR				
“DISPLAY PILOTS “ CERTIFICATE				
And send to MHSa Committee for consideration.				
to Address on Website.(Helicopter SIG )				
.				
<b>Minimum Score per Manoeuvre</b>	<b>4</b>	<b>4</b>	<b>4</b>	<b>4</b>
<b>SCORE SUB TOTALS</b>				
<b>SCORE FOR EACH FLIGHT (out of 100)</b>				
<b>PERCENTAGE</b>				
<b>AVE % OF BOTH FLIGHTS</b>				
<b>PASS MARK</b>	<b>60 %</b>			
<b>N.B. If less than the minimum score is achieved for any manoeuvre, the test will be deemed a failure.</b>				
<b>Please print the following</b>				
Pilot’s Name:	Club Name:			
Pilot’s Address:	Date:			
	Tel No.(W):			
	Cell No.:			
Pilot’s signature:	SAMAA No.:			
Judges Names 1 :	Signature:			
2 :	Signature:			
Club Chairman :	Signature:			